

FINISH :
TO 63 - FD 138 S

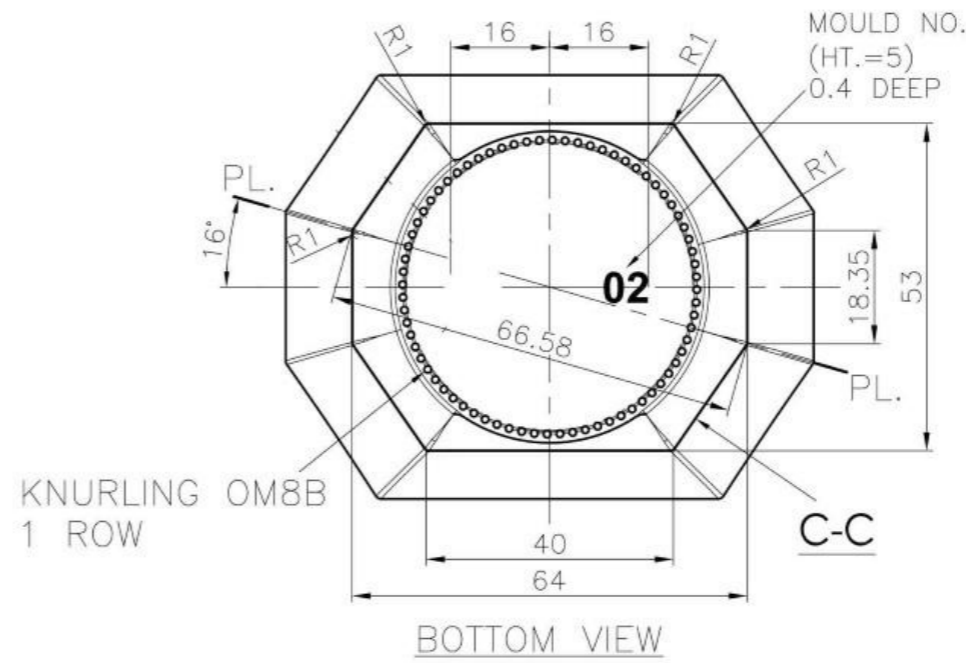
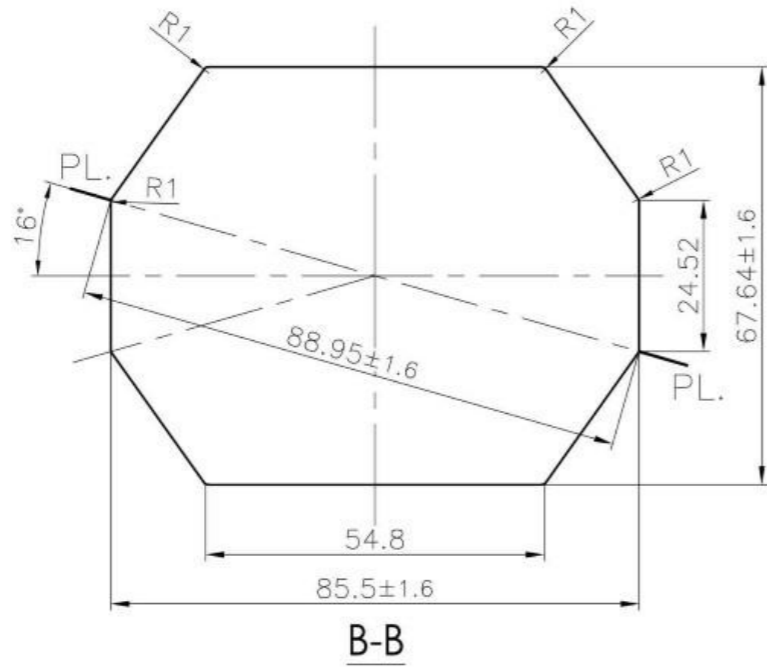

Ind	Changes	Name	Date

CUSTOMER	
ITEM	
WEIGHT 230g±10.5	FILL PT.
FILL PT. CAP.	COLOUR
BRIMFUL CAP. 385±6.5ml	DATE
NOM. HEADSPACE	CHK'D
DES'D BY	DRG NO.